



# WATT TRANSDUCERS

## MULTIPLE OUTPUT AC POWER TRANSDUCER

Model **PTB**

WATT TRANSDUCERS

### CONNECTION DIAGRAMS

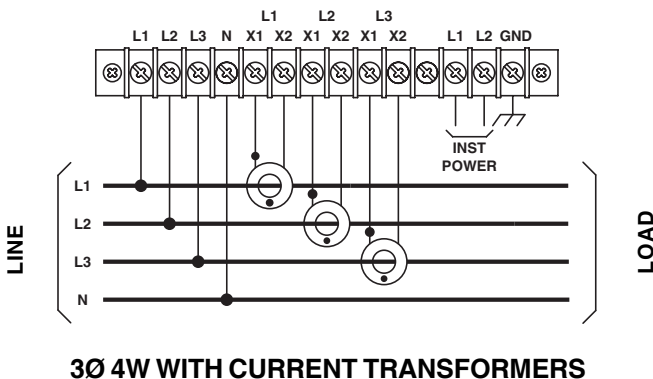
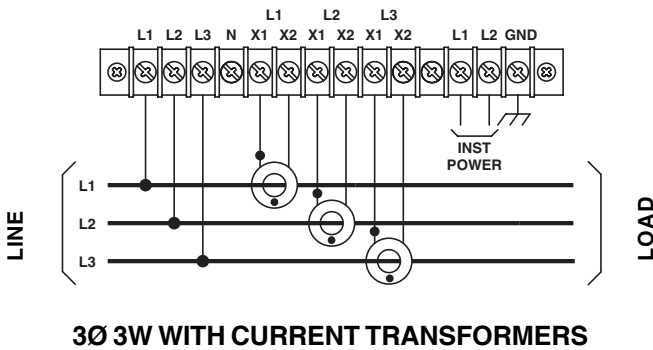
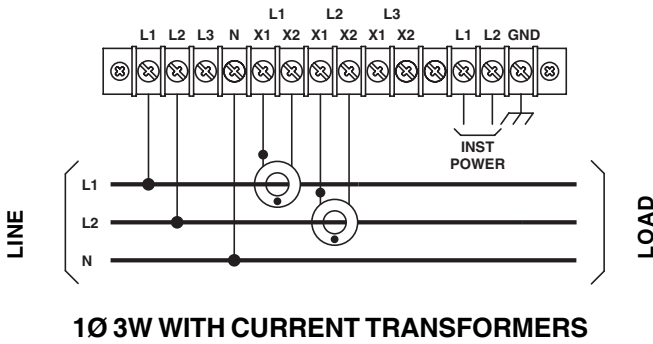
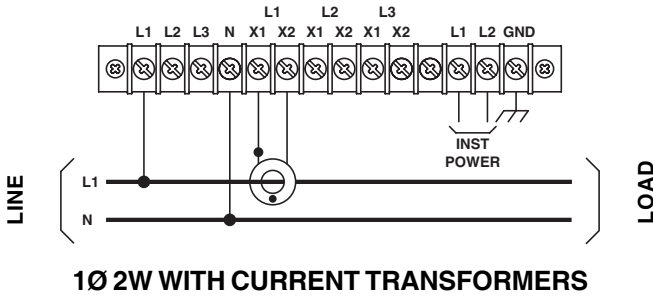

### DIMENSIONS

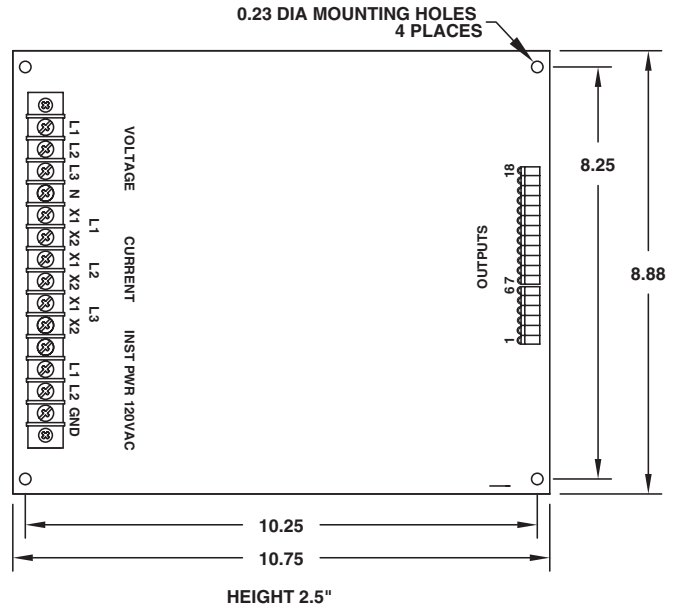

Optional NEMA Case ..... 12" X 10" X 4"  
 Mounting ..... 12.5" X 8.12", .22 Dia. Holes  
 Weight ..... 3.0 Lbs.

All Dimensions in Inches

### OUTPUT CONNECTIONS

1 Phase 2 Wire		3 Phase 3 Wire		3 Phase 4 Wire		1 Phase 3 Wire	
1	Watt-hour Relay	1	Watt-hour Relay	1	Watt-hour Relay	1	Watt-hour Relay
2		2		2		2	
3	NA	3	NA	3	NA	3	NA
4	NA	4	NA	4	NA	4	NA
5	Common	5	Common	5	Common	5	Common
6	Common	6	Common	6	Common	6	Common
7	Common	7	Common	7	Common	7	Common
8	Power Factor	8	Power Factor	8	Power Factor	8	Power Factor
9	Volt-Amperes	9	Volt-Amperes	9	Volt-Amperes	9	Volt-Amperes
10	Watts	10	Watts	10	Watts	10	Watts
11	Common	11	Common	11	Common	11	Common
12	NA	12	L3 Current	12	L3 Current	12	NA
13	NA	13	L2 Current	13	L2 Current	13	L2 Current
14	Current	14	L1 Current	14	L1 Current	14	L1 Current
15	Common	15	Common	15	Common	15	Common
16	NA	16	L1-L2 Voltage	16	L3-N Voltage	16	NA
17	NA	17	L2-L3 Voltage	17	L2-N Voltage	17	L2-N Voltage
18	Voltage	18	L3-L1 Voltage	18	L1-N Voltage	18	L1-N Voltage

**FLEX-CORE®**  
 Div. Morlan & Associates, Inc.  
 6625 McVey Blvd. Columbus, Ohio 43235

WWW.FLEX-CORE.COM  
 sales@flex-core.com

PHONE (614) 889-6152  
 TECH. ASSISTANCE (614) 876-8308  
 FAX # (614) 876-8538